

In-Line Amplifier

For strain gauge sensors

Model 9235

Code:	9235 EN
Delivery:	ex stock
Warranty:	24 months

CAD data 2D/3D for this device:
Download directly at www.traceparts.com
Info: refer to data sheet 80-CAD-EN

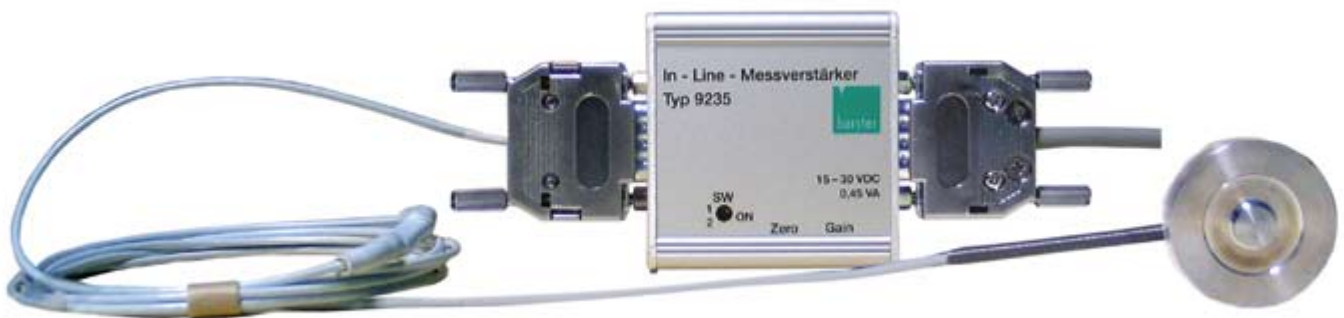

- Particularly space-saving and lightweight
- Voltage output 0 ... ± 10 V
- Designed as in-line measuring amplifier
- Non-interchangeable and short circuit-proof

Application

In practice the requirement often arises to convert the measurement signals of a sensor into a standard signal in the simplest possible manner in the immediate proximity of the sensor. This permits trouble-free, low-loss transmission of measured values over longer distances to an instrument board or plant controls.

Ideally suited for this purpose is the in-line measuring amplifier, which is inserted in between in the connection cable by means of plug contacts. Owing to its compact, robust design and low weight, it finds use in almost any application. Even movable locations subject to forces of acceleration, for example manipulators, present no problems. It is intended mainly for use of control cabinets in just about any location and is matched to a specific sensor. The aluminium housing is extremely sturdy and affords the greatest possible protection even in harsh environments.

Description

The in-line amplifier module itself is operated at voltages between 15 V and 30 V, from which it generates a stable excitation voltage to supply the sensor with power. The measurement signals of the sensor, normally ranging between 0 ... 5 mV and 0 ... 10 mV for bridge-connected strain gauges, are amplified to analog 0 ... 10 V.

The sensor characteristics are first roughly preset by means of DIP switches, through an opening in the housing. The fine-tuning of the instrument zero and amplification settings is performed by means of a multiple trimmer, accessible by screwdriver through holes drilled in the side of the housing. The amplifier connections are realized with sub-D plug and socket; short circuit-proof sensor power excitation and polarity reversal protection for the amplifier power excitation afford additional safety for installation. If the amplifier has to be mounted to its environment, this is done by clamping the housing or affixing it with an adhesive. The amplifier's cut-off frequency is > 1 kHz, its weight is < 65 g.

Technical Data

Connectable sensors

Strain gauges

Bridge resistance (full bridge):	350 Ω ... 5 kΩ
Connection technology:	4 wire
Sensor excitation voltage:	2.5 V
Excitation current:	10 mA max.
Power consumption:	approx 0.3 VA
Adjustable input:	0.8 mV/V ... 2.5 mV/V

Analog output

Voltage output:	0 ... ± 10 V
Output impedance:	470 Ω

General amplifier characteristics

Accuracy:	< 0,1 %
Temperature coefficient:	< 100 ppm/K
Power supply:	15 ... 30 V DC
Frequency response:	1 kHz
Operating temperature:	0 ... 60 °C

Plug connection model 9235

"Excitation and output" plug	pin 2 + excitation voltage
	pin 3 shield
	pin 5 - excitation voltage
	pin 7 ± output voltage
	pin 9 output ground

"Sensor" socket	pin 1 + sensor excitation
	pin 3 shield
	pin 5 - sensor excitation
	pin 6 + signal input
	pin 9 - signal input

Housing

Connections:	Sub-D plug / mating connector
Dimensions (W x H x D):	62 x 55 x 16 [mm]
Material:	Aluminium
Mounting:	clamp or stick on
Protection class:	IP40
Weight:	< 65 g
Humidity:	10 ... 80 %, not dewing

Default setting

Sensor output:	1.5 mV/V
----------------	----------

Example of a measuring chain

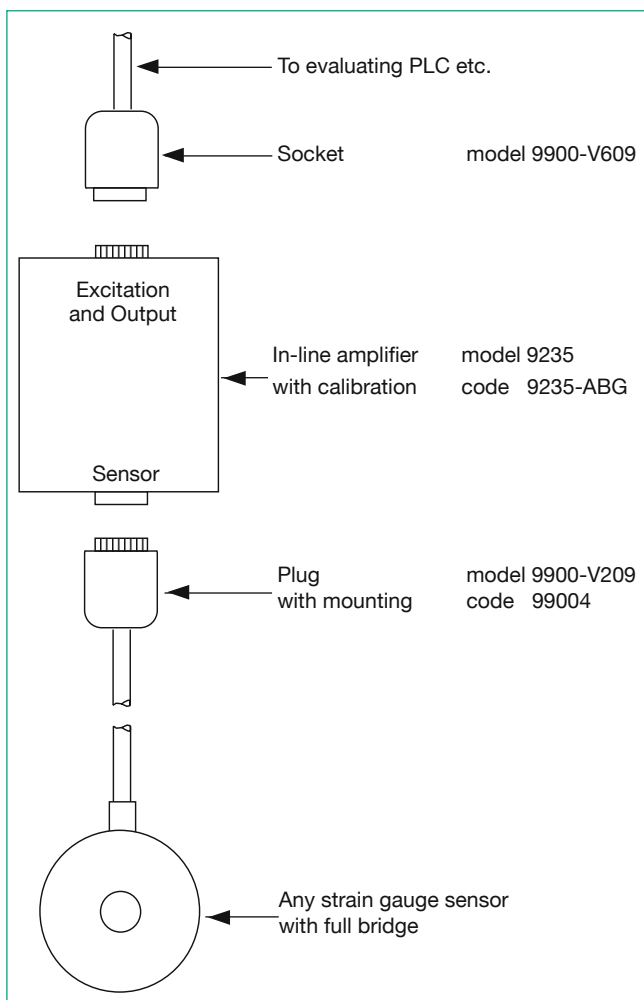

The CAD drawing (3D/2D) for this device can be imported online directly into your CAD system.

Download via www.burster.com or directly at www.traceparts.com. For further information about the burster traceparts cooperation refer to data sheet 80-CAD-EN.

Order Information

In-line amplifier with housing including cable tie bracket

Model 9235

Calibration of entire measuring chain

Consisting of sensor and amplifier model 9235

Order Code

9235-ABG

A sensor specific standard adjustment will be done, if no customer specific adjustment data are supplied.

Accessories

Connectors socket
plug

Model 9900-V609

Model 9900-V209

not part of scope of delivery