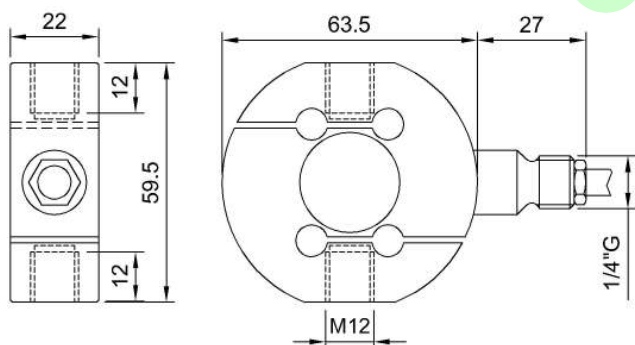

Dimensioni *Dimensions* [mm]

Stabilità a lungo termine
Long term high stability

 Download on www.aep.it

FACILE APPLICAZIONE
EASY APPLICATION

SOLLECITAZIONI DINAMICHE
DYNAMIC STRESSES

CODE (Class 00)	CODE (Class 0.5)	CODE (Class 1)	LOAD
CTSTM63500N005	CTSTM63500NI05	CTSTM63500NI15	0.5 kN
CTSTM631KNI005	CTSTM631KNI05	CTSTM631KNI15	1 kN
CTSTM632KNI005	CTSTM632KNI05	CTSTM632KNI15	2 kN
CTSTM633KNI005	CTSTM633KNI05	CTSTM633KNI15	3 kN
CTSTM635KNI005	CTSTM635KNI05	CTSTM635KNI15	5 kN



LENTE ITALIANO DI ACCREDITAMENTO

LAT N° 093
Calibration Centre
 The products are NOT covered by accreditation

 Certificato di Taratura ACCREDIA
A RICHIESTA

 ACCREDIA Calibration Certificate
ON REQUEST
Dati Tecnici
Technical Data



Classe di precisione: ISO 376	Accuracy class: ISO 376	00	0.5	1
CARICO NOMINALE	NOMINAL LOAD	0.5 - 1 - 2 - 3 - 5 kN		
ERRORI RELATIVI (al valore letto)	RELATIVE ERROR (at reading)			
a) ripetibilità 0°-120°-240° (b')	a) repeatability 0°-120°-240° (b')	≤ ± 0.050% ⁽¹⁾	≤ ± 0.090% ⁽¹⁾	≤ ± 0.155% ⁽¹⁾
b) interpolazione (fc)	b) interpolation (fc)	≤ ± 0.020% ⁽¹⁾	≤ ± 0.040% ⁽¹⁾	≤ ± 0.080% ⁽¹⁾
c) reversibilità (u)	c) reversibility (u)	≤ ± 0.070% ⁽¹⁾	≤ ± 0.100% ⁽¹⁾	≤ ± 0.200% ⁽¹⁾
d) zero (fo)	d) zero (fo)	≤ ± 0.010% F.S.	≤ ± 0.025% F.S.	≤ ± 0.025% F.S.
LINEARITA' / ISTERESI	LINEARITY / HYSTERESIS		≤ ± 0.02% F.S. ≤ ± 0.025% F.S.	
EFFETTO DELLA TEMPERATURA (10°C)	TEMPERATURE EFFECT (10°C)		≤ ± 0.025% F.S. ≤ ± 0.025% F.S.	
a) sullo zero	a) on zero		≤ ± 0.025% F.S.	
b) sulla sensibilità	b) on sensitivity		≤ ± 0.025% F.S.	
SENSIBILITA' NOMINALE	NOMINAL SENSITIVITY		2m V/V	
TOLLERANZA DI CALIBRAZIONE	SENSITIVITY TOLERANCE		≤ ± 0.1% F.S.	
RESISTENZA DI INGRESSO	INPUT RESISTANCE		350 ± 2Ω	
RESISTENZA DI USCITA	OUTPUT RESISTANCE		352 ± 2Ω	
RESISTENZA DI ISOLAMENTO	INSULATION RESISTANCE		>5 GΩ	
BILANCIAMENTO DI ZERO	ZERO BALANCE		≤ ± 1% F.S.	
ALIMENTAZIONE DI RIFERIMENTO	RECOMMENDED SUPPLY VOLTAGE		10 V	
ALIMENTAZIONE NOMINALE	NOMINAL SUPPLY VOLTAGE		1-15 V	
ALIMENTAZIONE MAX.	MAXIMUM SUPPLY VOLTAGE		18 V	
VALORI MECCANICI LIMITE RIFERITI AL CARICO NOMINALE :	MECHANICAL LIMIT VALUES REFERRED TO NOMINAL LOAD :			
a) carico di servizio	a) service load		120%	
b) carico limite	b) max permissible load		150%	
c) carico di rottura	c) breaking load		>300%	
d) massimo carico trasversale	d) max transverse load		50%	
e) carico dinamico limite	e) max permissible dynamic load		50%	
FRECCIA MAX. AL CARICO NOMINALE	DISPLACEMENT AT NOMINAL LOAD		~ 0.2 mm	
TEMPERATURA DI RIFERIMENTO	REFERENCE TEMPERATURE		+23°C	
CAMPO NOMINALE DI TEMPERATURA	TEMPERATURE NOMINAL RANGE		-10 / +40 °C	
TEMPERATURA DI ESERCIZIO	SERVICE TEMPERATURE		-10 / +70 °C	
TEMPERATURA DI STOCCAGGIO	STORAGE TEMPERATURE		-20 / +80 °C	
PESO	WEIGHT		~ 0.60 kg	
CLASSE DI PROTEZIONE (EN 60529)	PROTECTION CLASS (EN 60529)		IP67 (0.5 kN IP65 silicon cover)	
MATERIALE DINAMOMETRO	EXECUTION MATERIAL		Acciaio Inox / Stainless Steel	
LUNGHEZZA CAVO	CABLE LENGTH		5 m	
TESTE A SNODO SFERICO CONSIGLIATE	RECOMMENDED KNUCKLE JOINTS		DURBAL EM12	

⁽¹⁾ Errori percentuali calcolati al valore letto, min. 1/10 del carico nominale / Percentual errors referred to reading, min. 1/10 of the nominal load.

 A richiesta classificazioni secondo **ASTM E74** / Classifications according **ASTM E74** on request.

Applicazioni

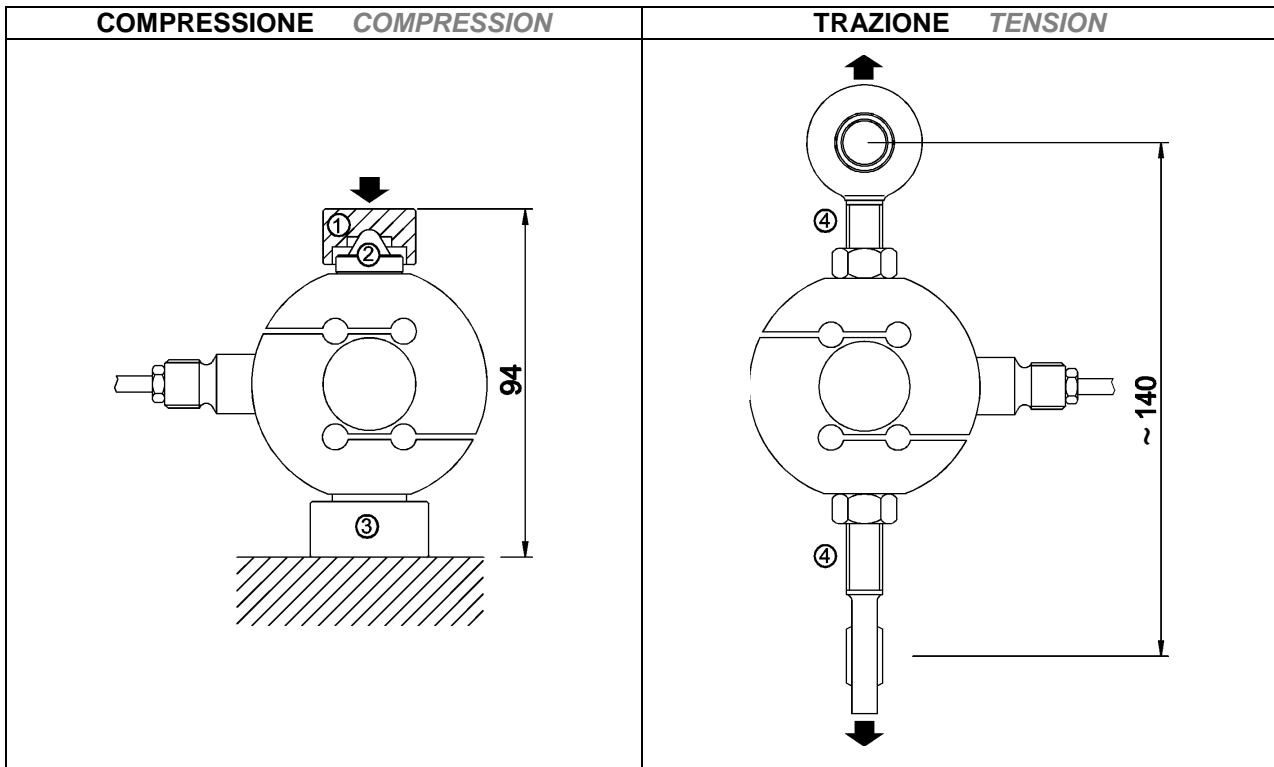
Applications



ATTENZIONE:



Verificare che la forza generata durante il montaggio degli accessori non superi il carico nominale.

Il peso del cavo può influire sulla misura, è pertanto consigliabile posizionarlo nella zona fissa dalla parte opposta al carico.

WARNING:



Be sure that the force generated during the accessories assembly does not exceed nominal load.

Cable weight can influence measurement, it is therefore recommended to place it at the opposite site of the load.

Accessori Accessories



CODE:		ACCESSORIES (optional):	ACCESSORI (opzionali):
CTIC13	①	Loading head.	Testa di carico
CTS18M12	②	Spherical load head.	Testa di carico sferica
CBC32M12	③	Mounting plate.	Base di carico.
CACCEM12L	④	Knuckle joints	Teste a snodo sferico

Collegamenti Elettrici Electrical Connections

Cavo schermato PVC 105°C, Ø 5.2 mm a 4 conduttori Ø 0.35mm² stagnati.

PVC 105°C shielded cable, Ø 5.2 mm with 4 tinned Ø 0.35mm² conductors.

Dynamometer	OUTPUT	CABLE	CAVO	MIL7M (optional)	DB9M (optional)
	EXCITATION+	Red	Rosso	C	3
	EXCITATION -	Black	Nero	B	4
	OUTPUT+	White	Bianco	A	1
	OUTPUT-	Yellow	Giallo	D	2
	Shield*	Shield*	Schermo*	E	5

* Collegato al corpo del dinamometro. / Connected to the dynamometer body.

AEP transducers



Dasa-Rägister
EN ISO 9001:2008
IQ-1100-01



LAT N° 093
Calibration Centre
The products are NOT covered by accreditation



Production Quality Assurance Certified n° TÜV 06 ATEX 553793 Q

41126 Cognento (MODENA) Italy Via Bottego 33/A Tel:+39-(0)59-346441 Fax:+39-(0)59-346437 E-mail: aep@aep.it

Al fine di migliorare le prestazioni tecniche del prodotto, la società si riserva di apportare variazioni senza preavviso.
In order to improve the technical performances of the product, the company reserves the right to make any change without notice.